



1 GHz GainMaker Broadband Amplifier Platform Housing Strand Clamp Offset Bracket Technical Bulletin

Overview

Some installations require that a GainMaker® node or system amplifier housing be mounted directly to a system strand cable without interfering with other service cables attached to the strand.

In such installations, an offset strand clamp bracket (not supplied with the housing) can be used to lower the mounting position of the GainMaker node or system amplifier housing. The customer-selected offset mounting bracket permits other service cables to pass between the strand cable and the housing, thereby avoiding interference.

Purpose

This document provides customers with important installation information when using customer-selected offset strand clamp brackets to mount a GainMaker node or system amplifier housing.

Audience

This document is intended for authorized service personnel who have experience working with similar equipment. The service personnel should have appropriate background and knowledge to complete the procedures described in this document.

Qualified Personnel

Only appropriately qualified and skilled service personnel should attempt to install, operate, maintain, and service this product.



WARNING:

Allow only qualified and skilled personnel to install, operate, maintain, and service this product. Otherwise, personal injury or equipment damage may occur.

Related Publications

You may find the following publications useful as you implement the procedures in this document.

- *1 GHz GainMaker Broadband Amplifier Platform Housing Stripped Mounting Hole Technical Bulletin (for Internal Use Only)*, part number 4025769
- *1 GHz GainMaker Broadband Amplifier Platform Reverse Segmentable High Gain Balanced Triple Node Installation and Operation Guide*, part number 4015253
- *1 GHz GainMaker Broadband Amplifier Platform Node Installation and Operation Guide*, part number 4008353
- *1 GHz GainMaker Broadband High Gain Balanced Triple (HGBT) RF Redundant Node Installation and Operation Guide*, part number 4011881
- *1 GHz GainMaker Broadband Amplifier Platform System Amplifier Modules and Housings Installation and Operation Guide*, part number 4009928

Document Version

This is the second release of this document.

In This Document

- Installation Procedure 3
- Method Using Existing Mounting Screws 4
- Method Using New Mounting Screws 6
- For Information 8

Installation Procedure

This section describes two methods for installing offset strand clamp brackets.

- The first method uses the 5/6-18 x 3/4 thread-forming screws provided with the GainMaker housing, and requires additional 5/16-inch stainless steel flat washers for use as spacers.
- The second method reuses the existing strand clamp brackets as spacers, and requires the use of new, longer 5/16-inch thread-forming screws to compensate for the thickness of the offset strand clamp brackets selected by the customer.



CAUTION:

Add screw length as needed to fully compensate for the thickness of the chosen offset mounting bracket, and confirm that the longer screws fully engage the threads in the GanMaker housing. Insufficient screw length may cause stripped threads in the housing.

Choose either method as convenient. The new hardware needed for both methods is commonly available from a home improvement retailer or other local source.

Required Tools and Hardware

The following materials are required for each installation method.

Method Using Existing Thread Forming Screw

- 1/2-inch combination wrench (open end or box end)
- Offset strand clamp bracket (available from various third-party suppliers), one for each strand clamp to be replaced
- 5/16-inch stainless steel split lock washer, one for each strand clamp (if not provided with housing)
- 5/16-inch stainless steel flat washer, one for each strand clamp bracket

Method Using Longer Thread Forming Screw

- 1/2-inch combination wrench (open end or box end)
- Offset strand clamp bracket (available from various third-party suppliers), one for each strand clamp to be replaced
- 5/16-inch stainless steel split lock washer, one for each strand clamp (if not provided with housing)
- 5/16-18 x 7/8 stainless steel hex head screw, one for each strand clamp bracket

Method Using Existing Mounting Screws

Complete the following steps to install each of two offset strand clamp brackets using the 5/16-18 x 3/4 thread-forming screws supplied with the housing.

- 1 Use a 1/2-inch wrench to remove one set of existing strand clamp hardware.

Note: Save the thread-forming screw for reuse as well as the lock washer, if provided. Discard the existing strand clamp.

- 2 Install a 5/16-inch stainless steel lock washer on the 5/16-18 x 3/4 thread-forming screw.

Note: If a lock washer was not provided on the original housing, obtain a new split lock washer from a home improvement retailer or other convenient source.

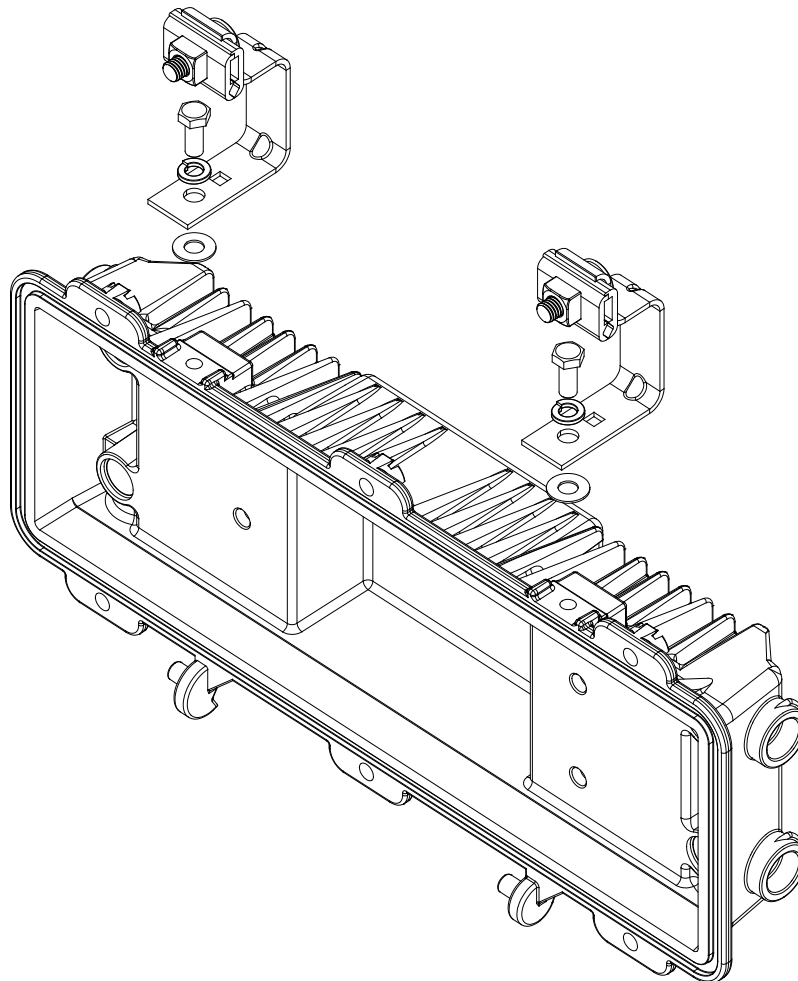

- 3 Insert the screw with lock washer through the mounting hole of one offset bracket.

- 4 Install a 5/16-inch stainless steel flat washer on the end of the screw that now extends through the offset bracket mounting hole.
Note: The flat washer acts as a spacer to provide clearance between the housing and the mounting bracket, so that the housing lid will close properly.
- 5 Insert the screw into the threaded housing and tighten the screw to 5 ft-lb to 8 ft-lb (6.8 Nm to 10.9 Nm).
- 6 Verify that the housing opens and closes properly with the new strand-mounting hardware installed.
- 7 Repeat steps 1-6 above to install the remaining offset strand clamp bracket.



CAUTION:

Do not assemble the offset strand clamp bracket without first verifying that the new hardware will permit the housing to open and close properly.

Method Using New Mounting Screws

Complete the following steps to install each of two offset strand clamp brackets using new mounting screws.

- 1 Use a 1/2-inch wrench to remove one set of existing strand clamp hardware.

Note: Save the existing strand clamp for reuse as well as the lock washer, if provided on the housing. Discard the existing thread-forming screw.

- 2 Install a 5/16-inch stainless steel lock washer on a new 5/16-18 x 7/8 hex head screw.

Note: If a lock washer was not provided on the original housing, obtain a new split lock washer from a home improvement retailer or other convenient source.

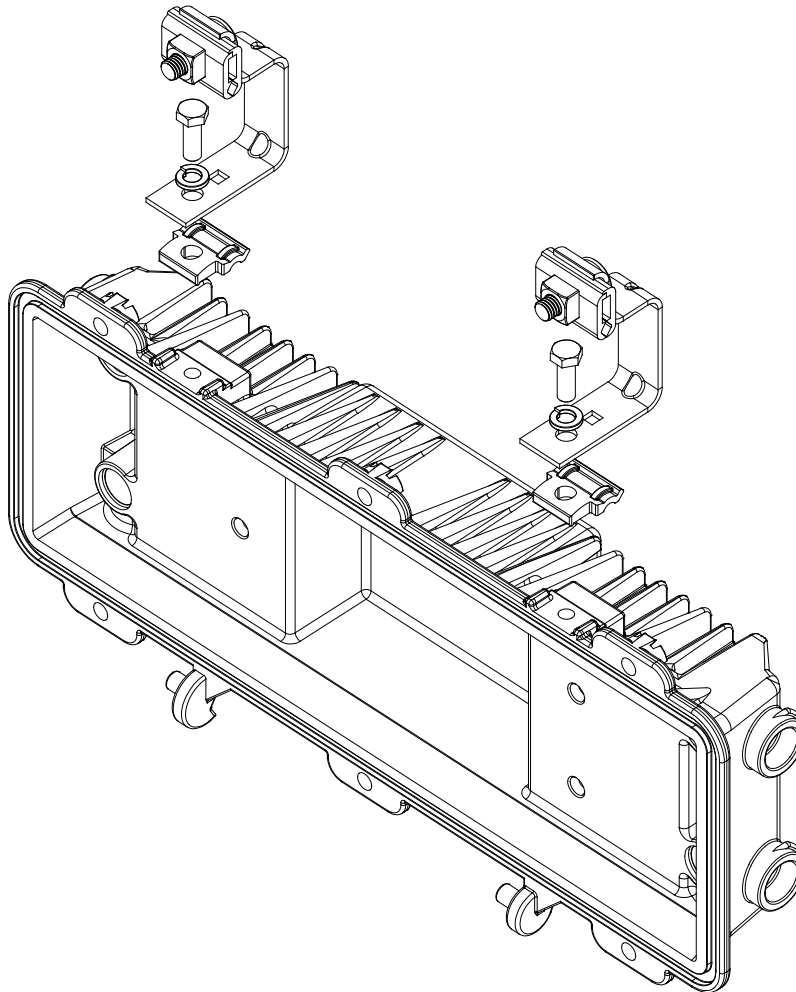

- 3 Insert the screw with lock washer through the mounting hole of one offset bracket.

- 4 Install an existing strand clamp on the end of the screw that now extends through the offset bracket mounting hole.
Note: The strand clamp acts as a spacer to provide clearance between the housing and the mounting bracket, so that the housing lid will close properly.
- 5 Insert the screw into the threaded housing and tighten the screw to 5 ft-lb to 8 ft-lb (6.8 Nm to 10.9 Nm).
- 6 Verify that the housing opens and closes properly with the new strand-mounting hardware installed.
- 7 Repeat steps 1-6 above to install the remaining offset strand clamp bracket.



CAUTION:

Do not assemble the offset strand clamp bracket without first verifying that the new hardware will permit the housing to open and close properly.

For Information

For Information

If You Have Questions

If you have technical questions, call Cisco Services for assistance. Follow the menu options to speak with a service engineer.



Cisco Systems, Inc.
5030 Sugarloaf Parkway, Box 465447
Lawrenceville, GA 30042

678 277-1120
800 722-2009
www.cisco.com

Cisco and the Cisco logo are trademarks or registered trademarks of Cisco and/or its affiliates in the U.S. and other countries. To view a list of Cisco trademarks, go to this URL:

www.cisco.com/go/trademarks

Third party trademarks mentioned are the property of their respective owners.

The use of the word partner does not imply a partnership relationship between Cisco and any other company. (1110R)

Product and service availability are subject to change without notice.

© 2008, 2012 Cisco and/or its affiliates. All rights reserved.

September 2012 Printed in USA

Part Number 78-4025768-01 Rev B