

يـمـرـهـلـا مـاـظـنـلـا يـلـع ةـيـمـوـسـر ةـمـاـع ةـرـظـن (SDH) نـمـاـزـتـمـلـا يـمـقـرـلـا

المحتويات

المقدمة
المتطلبات الأساسية
المتطلبات
المكونات المستخدمة
الاصطلاحات
تحليل SDH
إرتباط SDH
إطارات STM1
STM1 SOH
توافق VC4
التدرج الهرمي لـ SDH
تفاعلات صيانة SDH
الإنذار ومعايير الكشف
وحدات بايت STM1 SOH و HO-POH و LO-POH
معلومات ذات صلة

[المقدمة](#)

يقدم هذا المستند نظرة عامة على النظام الهرمي الرقمي المتزامن (SDH) ممثلا في الصور.

[المتطلبات الأساسية](#)

[المتطلبات](#)

لا توجد متطلبات أساسية خاصة لهذا المستند.

[المكونات المستخدمة](#)

لا يقتصر هذا المستند على إصدارات برامج ومكونات مادية معينة.

[الاصطلاحات](#)

راجع [اصطلاحات تلميحات Cisco التقنية للحصول على مزيد من المعلومات حول اصطلاحات المستندات.](#)

[تحليل SDH](#)

توفر هذه الأقسام نظرة عامة على SDH بتنسيق رسومي.

إرتباط SDH

يوضح هذا المخطط شكل إرتباط SDH.

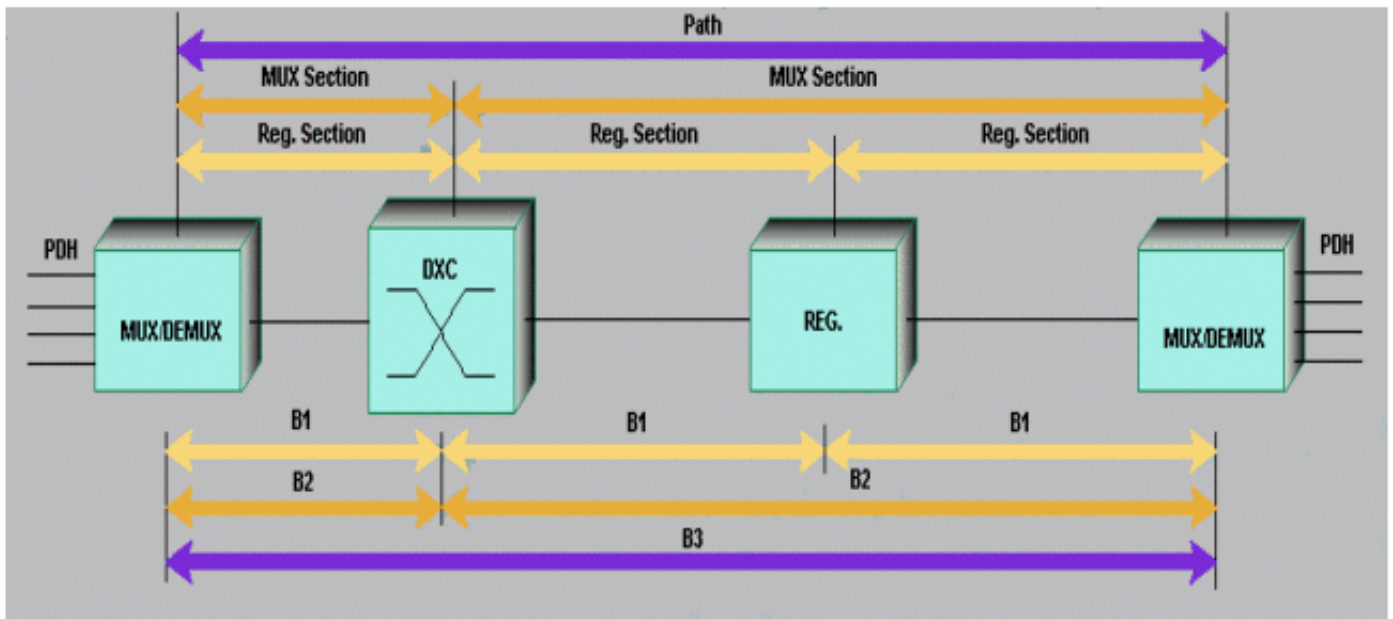

إطارات STM1

يوضح هذا المخطط بنية إطار وحدة النقل المتزامنة من المستوى 1 (STM1).

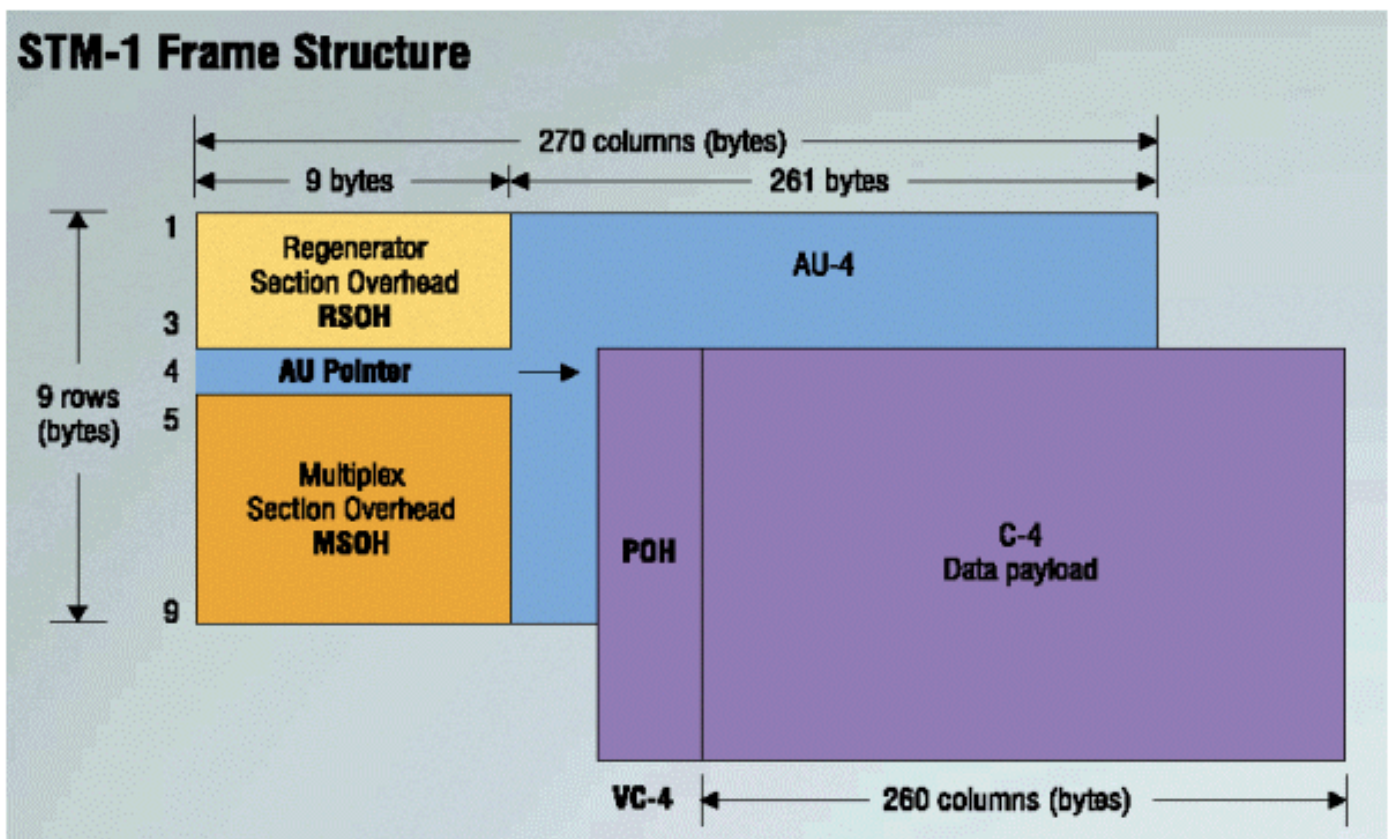

STM1 SOH

يوضح هذا المخطط شكل قسم (SOH over STM1).

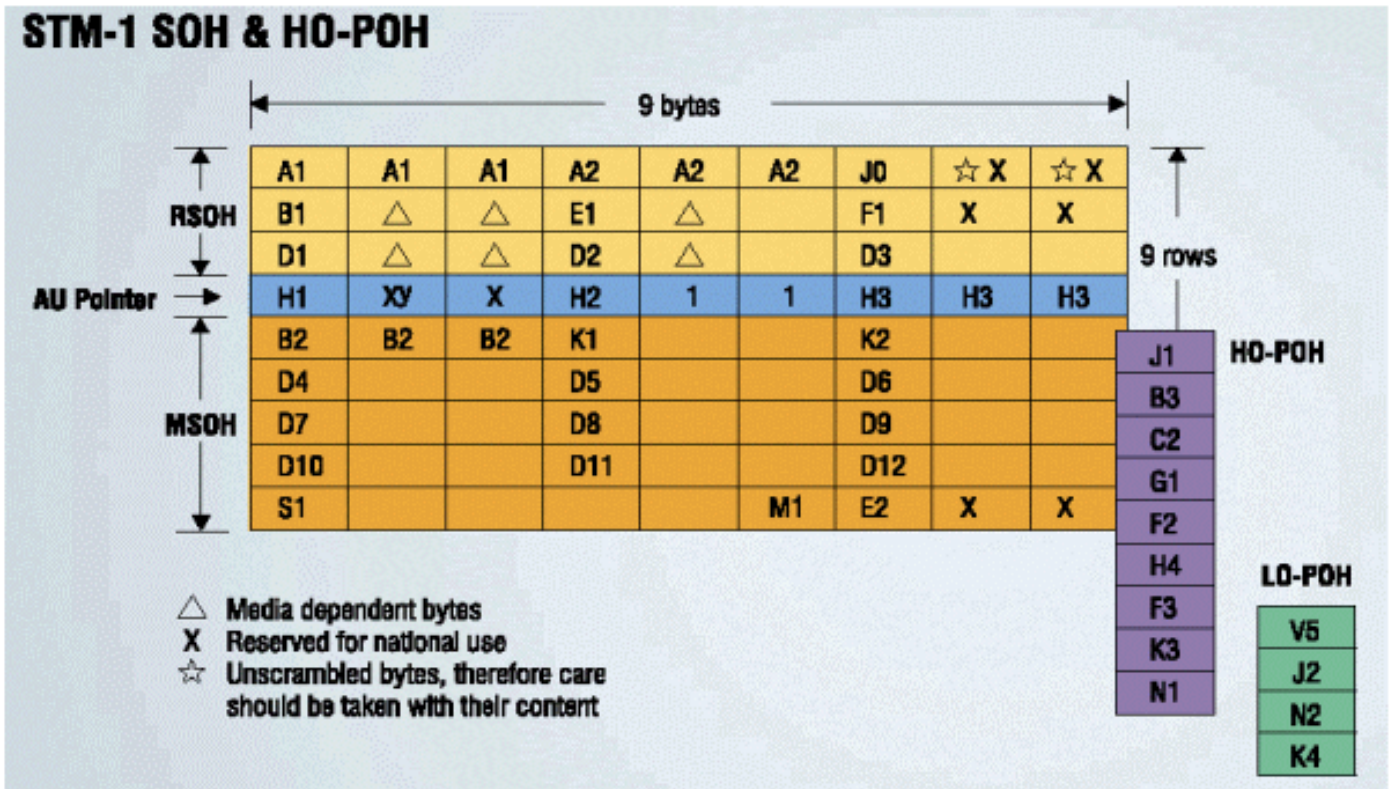

توافق VC4

يبحث هذا المخطط في تنسيق VC4.

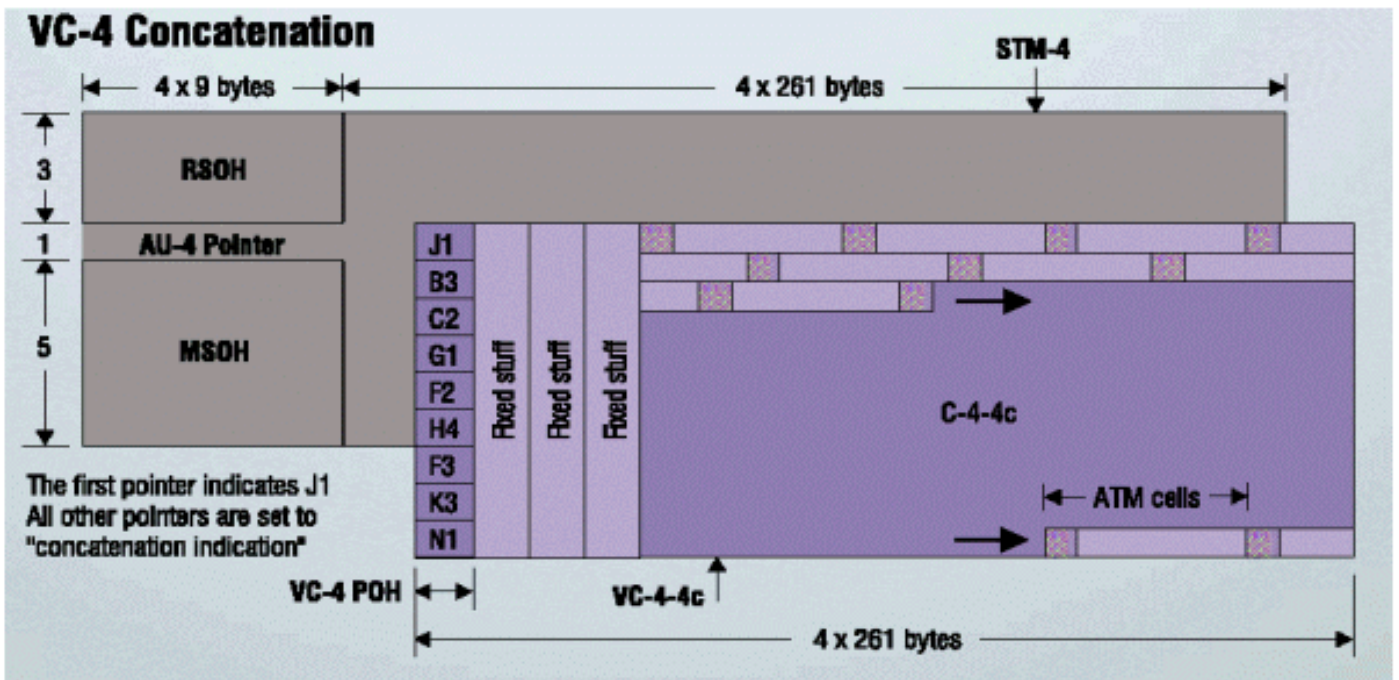

التدرج الهرمي ل SDH

يعرض هذا المخطط هيكل SDH.

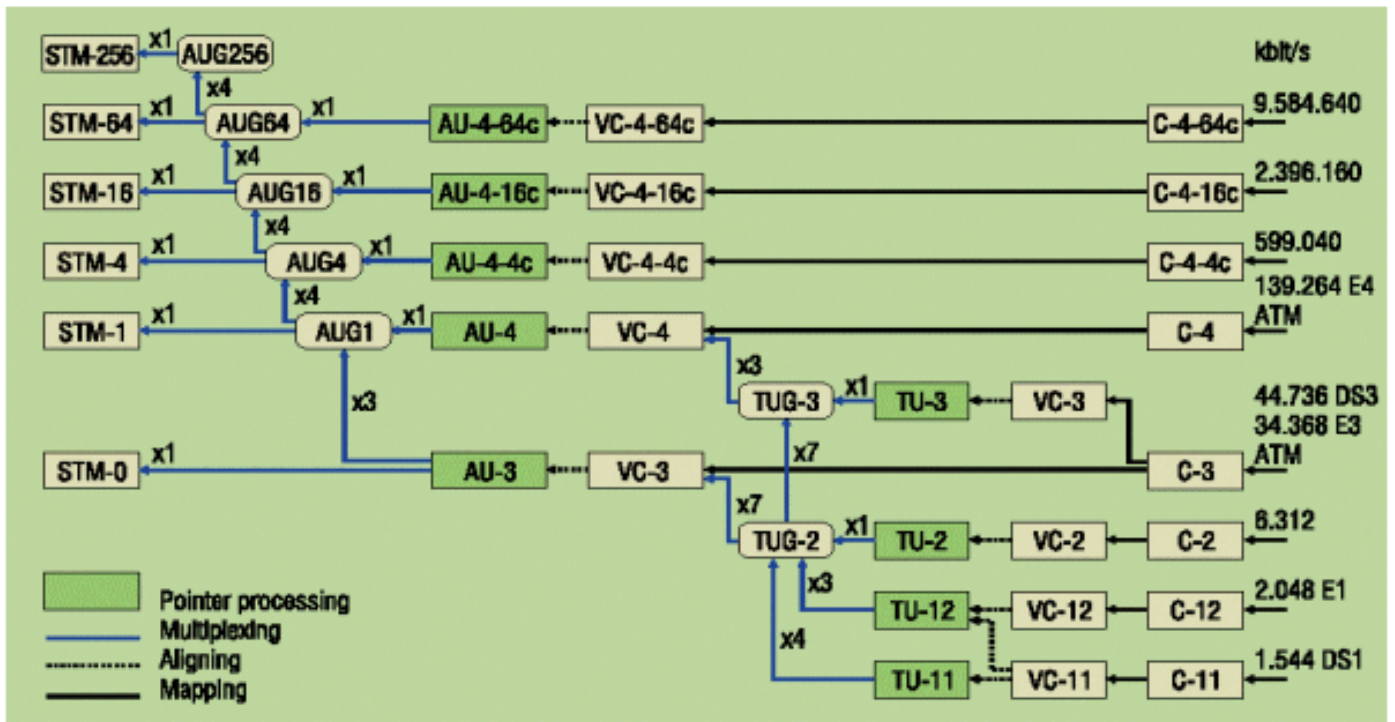

تفاعلات صيانة SDH

يوضح هذا المخطط كيفية ظهور تفاعلات صيانة SDH.

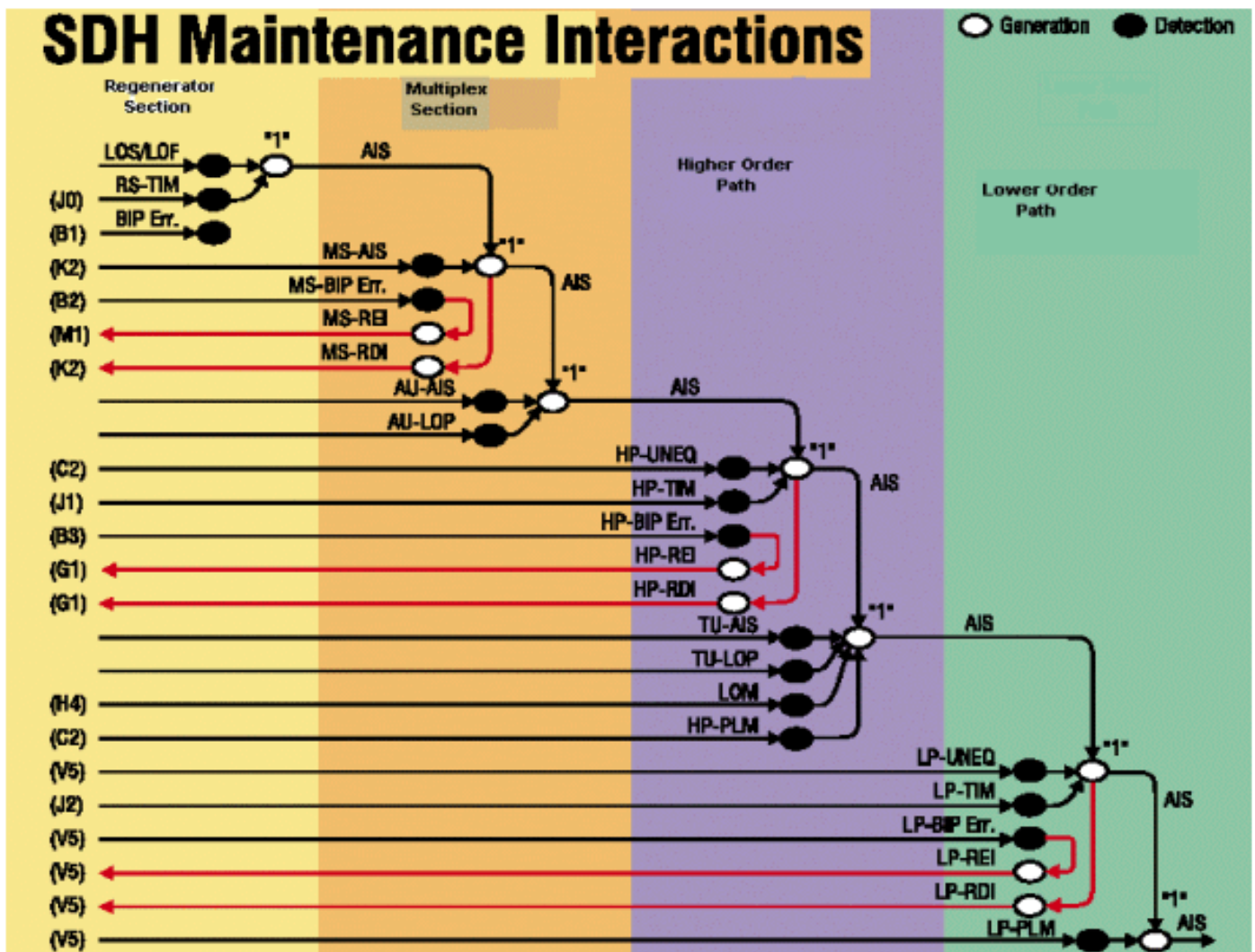

ينظر هذا الجدول إلى ما تعنيه الإذارات ومعايير كشفها.

	Anomalies/Defects	Detection criteria	ITU-T Rec.
LOS	Loss of Signal	Drop of incoming optical power level causes high bit error rate	G.958
OOF	Out of Frame	A1, A2 incorrect for $\geq 625 \mu s$	G.783
LOF	Loss of Frame	If OOF persists for $\geq 3 ms$ (to be defined)	G.783
RS BIP Error	Regenerator Section BIP Error (B1)	Mismatch of the recovered and computed BIP-8 covers the whole STM-N frame	G.783
RS-TIM	Regenerator Section Trace Identifier Mismatch	Mismatch of the accepted and expected Trace Identifier in byte J0	G.783
MS BIP Error	Multiplex Section BIP Error (B2)	Mismatch of the recovered and computed N x BIP-24 covers the whole frame, except RSOH	G.783
MS-AIS	Multiplex Section AIS	K2 (bits 6, 7, 8) = 111 for ≥ 3 frames	G.783
MS-REI	Multiplex Section Remote Error Indication	Number of detected B2 errors in the sink side encoded in byte M1 of the source side	G.707
MS-RDI	Multiplex Section Remote Defect Ind.	K2 (bits 6, 7, 8) = 110 for $\geq z$ frames ($z = 3 - 5$)	G.783
AU-AIS	Administrative Unit AIS	All *1* in the AU pointer bytes H1, H2	G.783
AU-LOP	Administrative Unit Loss of Pointer	8 - 10 NDF enable, 8 - 10 Invalid pointers	G.783
HP BIP Error	HO Path BIP Error (B3)	Mismatch of the recovered and computed BIP-8 covers entire VC-n	G.783
HP-UNEQ	HO Path Unequipped	C2 = "0" for ≥ 5 frames	G.783
HP-TIM	HO Path Trace Identifier Mismatch	Mismatch of the accepted and expected Trace Identifier in byte J1	G.783
HP-REI	HO Path Remote Error Indication	Number of detected B3 errors in the sink side encoded in byte G1 (bits 1, 2, 3, 4) of the source side	G.707
HP-RDI	HO Path Remote Defect Indication	G1 (bit 5) = 1 for $\geq z$ frames ($z = 3, 5$ or 10)	G.783
HP-PLM	HO Path Payload Label Mismatch	Mismatch of the accepted and expected Payload Label in byte C2	G.783
TU-LOM	Loss of Multiframe	H4 (bits 7, 8) multiframe not recovered for X m, X = 1 - 5 ms	G.783
TU-AIS	Tributary Unit AIS	All *1* in the TU pointer bytes V1, V2	G.783
TU-LOP	Loss of Pointer	8 - 10 NDF enable, 8 - 10 Invalid pointers	G.783
LP BIP Error	LO Path BIP Error	Mismatch of the recovered and computed BIP-8 (B3) or BIP-2 (V5 bits 1, 2) covers entire VC-n	G.783
LP-UNEQ	LO Path Unequipped	VC-3: C2 = *0* for ≥ 5 frames, VC-m ($m = 2, 11, 12$): V5 (bits 5, 6, 7) = 000 for ≥ 5 multiframe	G.783
LP-TIM	LO Path Trace Identifier Mismatch	Mismatch of the accepted and expected Trace Identifier in byte J1 (VC-3) or J2	G.783
LP-REI	LO Path Remote Error Indication	VC-3: Number of detected B3 errors in the sink side encoded in byte G1 (bits 1, 2, 3, 4) of the source side, VC-m ($m = 2, 11, 12$): If one or more BIP-2 errors detected in the sink side, byte V5 (bits 3) = 1 on the source side	G.707
LP-RDI	LO Path Remote Defect Indication	VC-3: G1 (bit 5) = 1 for $\geq z$ frames, VC-m ($m = 2, 11, 12$): V5 (bit 8) = 1 for $\geq z$ multiframe ($z = 3, 5$ or 10)	G.783
LP-PLM	LO Path Payload Label Mismatch	Mismatch of the accepted and expected Payload Label in byte C2 or V5 (bits 5, 6, 7)	G.783

وحدات بايت STM1 SOH و HO-POH و LO-POH

توفر هذه المخططات وصفا لجميع وحدات الباييت من STM1 SOH والنققات العامة للمسار عالي الترتيب (HO-) (POH) والنققات العامة لمسار انخفاض الطلب (LO-POH).

RSOH Regenerator Section Overhead

A1, A2: Indicates the beginning of the STM-1 frame (A1:11110110, A2:00101000). The frame alignment word of an STM-N frame is composed of 3*N A1 bytes followed by 3*N A2 bytes.

J0: Regenerator section trace. Used to transmit a section access point identifier so that a section receiver can verify its continued connection to the intended transmitter.

Z0: Spare. Reserved for future international standardization.

B1: Regenerator section error monitoring. The BIP-8 is computed over all bits of the previous STM-N frame after scrambling and is placed in the B1 byte of the current frame before scrambling.

E1: Provides orderwire channels for voice communication between regenerators.

F1: Reserved for user purposes (e.g. temporary data/voice channel connections for special maintenance purposes).

D1 - D3: Data communication channels (DCC). A 192 kbit/s channel used from a central location for alarms, control, monitoring and administration functions.

AU Pointers

H1, H2: Pointer bytes. The pointer contained in these bytes designates the location of the VC-n frame. The last ten bits (b7 - b16) carry the pointer value (binary number with a range of 0 to 782).

H3: Pointer action byte. It is used for frequency justification. Depending on the pointer value, this byte is used to adjust the fill input buffers. It only carries valid information in the event of negative justification, otherwise it's not defined.

MSOH Multiplex Section Overhead

B2: Multiplex section error monitoring. The BIP-N *24 is used to determine if a transmission error has occurred over a multiplex section. It is computed over all bits of the previous STM-N frame except for the first three rows and is placed in the B2 byte of the current frame.

K1, K2: Allocated for APS (Automatic Protection Switching) signaling for the protection of the multiplex section.

Linear APS messages

ITU-T G.841 protection switching protocol	
K1 byte	Condition
b1 - b4	
1111	Lockout of protection
1110	Forced switch
1101	Signal fail high priority
1100	Signal fall low priority
1011	Signal degrade high priority
1010	Signal degrade low priority
1001	Unused
1000	Manual switch
0111	Unused
0110	Wait-to-restore
0101	Unused
0100	Exercise
0011	Unused
0010	Reserve request
0001	Do not revert
0000	No request
b5 - b8	Selects channel used by APS messages

K2 byte	Condition
b1 - b4	Selects bridged channel used
b5	Determines automatic protection switch architecture
b6 - b8	000 = Reserved for future use 001 = Reserved for future use 010 = Reserved for future use 011 = Reserved for future use 100 = Reserved for future use 101 = Reserved for future use 110 = MS-RDI 111 = MS-AIS

Ring APS messages

ITU-T G.841 protection switching protocol	
K1 byte	Condition
b1 - b4	
1111	Lockout of protection (span) or signal fall (protection)
1110	Forced switch (span)
1101	Forced switch (ring)
1100	Signal fall (span)
1011	Signal fail (ring)
1010	Signal degrade (protection)
1001	Signal degrade (span)
1000	Signal degrade (ring)
0111	Manual switch (span)
0110	Manual switch (ring)
0101	Wait-to-restore
0100	Exerciser (span)
0011	Exerciser (ring)
0010	Reserve request (span)
0001	Reserve request (ring)
0000	No request
b5 - b8	Destination node ID

K2 byte	Condition
b1 - b4	Source node ID
b5	Path code: 0 = short path; 1 = long path
b6 - b8	000 = Idle 001 = Bridged 010 = Bridged and switched 011 = Reserved for future use 100 = Reserved for future use 101 = Reserved for future use 110 = MS-RDI

D4 - D12: Data communication channels (DCC). A 576 kbit/s channel is used from a central location for alarms, control, monitoring and administration functions.

S1: Synchronization status. Bits 5 - 8 are used to carry the synchronization messages. The following is an assignment of bit patterns to the four synchronization levels agreed to within ITU-T.

S1 byte b5 - b8	SDH synchronization quality level description
0000	Quality unknown (existing synchronization network)
0001	Reserved
0010	Rec. G.811
0011	Reserved
0100	SSU-A
0101	Reserved
0110	Reserved
0111	Reserved
1000	SSU-B
1001	Reserved
1010	Reserved
1011	(SEC) SDH Equipment Source
1100	Reserved
1101	Reserved
1110	Reserved
1111	Do not use for synchronization

M1: Allocated for use as a multiplex section REI. Conveys the count of interleaved bit blocks detected in error by B2.

E2: Provides orderwire channels for voice communication between multiplexers.

H0-POH Higher Order Path Overhead

J1: The first byte in the virtual container. Its location is indicated by the AU pointer. A 64-byte free format string or a 16-byte frame is transmitted so that a path receiving terminal can verify its continued connection to the intended transmitter.

B3: Higher order path error monitoring. The BIP-8 is calculated over all bits of the previous VC-n. Computed value is placed in the B3 byte.

C2: Signal label. Indicates the composition or the maintenance status of the VC-n.

C2 byte coding

b1 - b4	b5 - b8	Hex code	Interpretation
0000	0000	00	Unequipped or supervisory-unequipped
0000	0001	01	Equipped – nonspecific
0000	0010	02	TUG structure
0000	0011	03	Locked TU-n
0000	0100	04	Asynchronous mapping of 34 368 kbit/s or 44 736 kbit/s into the container-3 (C-3)
0001	0010	12	Asynchronous mapping of 139 264 kbit/s into the container-4 (C-4)
0001	0011	13	ATM mapping
0001	0100	14	MAN (DQDB) mapping
0001	0101	15	FDDI mapping
0001	0110	16	Mapping of HDLC framed signal
1100	1111	CF	Mapping of HDLC framed signal
1111	1110	FE	Test signal, 0.181 specific mapping
1111	1111	FF	VC-AIS

G1: Path status. Conveys the path status and performance back to the trail termination source as detected by a trail termination sink.

REI				RDI			Spare
b1	b2	b3	b4	b5	b6	b7	b8

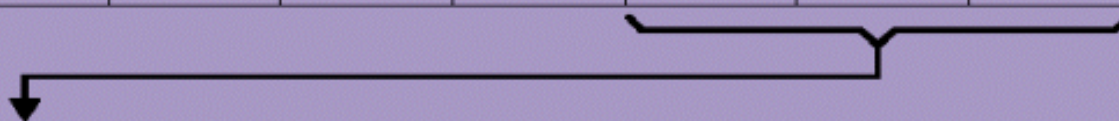

G1 (b5 - b7) coding and Interpretation

b5 - b7	Meaning	Triggers
000	No remote defect	No remote defect
001	No remote defect	No remote defect
010	Remote payload defect	LCD
011	No remote defect	No remote defect
100	Remote defect	AIS, LOP, TIM, UNEQ (or PLM, LCD)
101	Remote server defect	AIS, LOP
110	Remote connectivity defect	TIM, UNEQ
111	Remote defect	AIS, LOP, TIM, UNEQ (or PLM, LCD)

F2, F3: Path user channels. Allocated for user communication purposes between path elements and are payload dependent.

H4: Position and sequence indicator. Provides a multiframe and sequence indicator for virtual concatenation and a generalized position indicator for payloads.

K3: (b1 - b4) are allocated for higher order path Automatic Protection Switching (APS). (b5 - b8) are allocated for future use. Have no defined value. The receiver is required to ignore their content.

N1: Network operator byte. Allocated to provide a Tandem Connection Monitoring (TCM) function.

N1 byte structure



b7 - b8 multiframe structure

Frame #	Bits 7 and 8 definition
1 - 8	Frame alignment signal: 1111 1111 1111 1110
9 - 12	TC-APId byte #1 [1 C ₁ C ₂ C ₃ C ₄ C ₅ C ₆ C ₇]
13 - 16	TC APId byte #2 [0 X X X X X X X]
17 - 20	TC APId byte #3 [0 X X X X X X X]
⋮	⋮
⋮	⋮
65 - 68	TC APId byte #15 [0 X X X X X X X]
69 - 72	TC APId byte #16 [0 X X X X X X X]
73 - 76	TC-RDI, ODI and reserved

Structure of frames # 73 - 76 of the b7 - b8 multiframe

TC-RDI, ODI and reserved capacity

Frame #	b7 definition	b8 definition
73	Reserved (default = "0")	TC-RDI
74	ODI	Reserved (default = "0")
75	Reserved (default = "0")	Reserved (default = "0")
76	Reserved (default = "0")	Reserved (default = "0")

LO-POH Lower Order Path Overhead

(for VC-11, VC-12, VC-2)

V5: Provides the functions of error checking, signal label and path status.

BIP-2		REI	RFI	Signal label			RDI
b1	b2	b3	b4	b5	b6	b7	b8

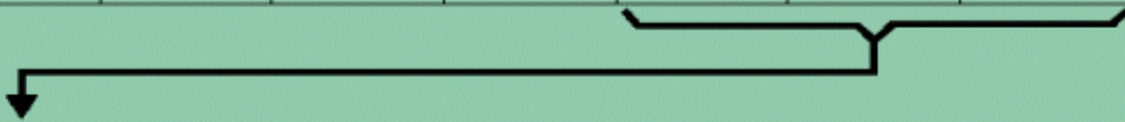

b5	b6	b7	Meaning
0	0	0	Unequipped or supervisory-unequipped
0	0	1	Equipped – nonspecific
0	1	0	Asynchronous
0	1	1	Bit synchronous
1	0	0	Byte synchronous
1	0	1	Reserved for future use
1	1	0	Test signal, 0.181 specific mapping
1	1	1	VC-AIS

J2: Lower order path trace Identifier. A 16-byte frame is transmitted so that a path receiving terminal can verify its continued connection to the intended transmitter.

N2: Network operator byte. Allocated to provide a Tandem Connection Monitoring (TCM) function

N2 byte structure

BIP-2		"1"	Incoming AIS	TC-REI	OEI	TC-APId, TC-RDI ODI, reserved	
b1	b2	b3	b4	b5	b6	b7	b8



b7 - b8 multiframe structure

Frame #	b7 - b8 definition
1 - 8	Frame alignment signal: 1111 1111 1111 1110
9 - 12	TC-APId bytes #1 [1 C ₁ C ₂ C ₃ C ₄ C ₅ C ₆ C ₇]
13 - 16	TC APId byte #2 [0 XXXXXXXX]
17 - 20	TC APId byte #3 [0 XXXXXXXX]
⋮	⋮
65 - 68	TC APId byte #15 [0 XXXXXXXX]
69 - 72	TC APId byte #16 [0 XXXXXXXX]
73 - 76	TC-RDI, ODI and reserved

Frame #	b7 definition	b8 definition
73	Reserved (default = "0")	TC-RDI
74	ODI	Reserved (default = "0")
75	Reserved (default = "0")	Reserved (default = "0")
76	Reserved (default = "0")	Reserved (default = "0")

K4: (b1 - b4) are allocated for higher order path Automatic Protection Switching (APS). (b5 - b7) are reserved for an optional use. If this option is not used, these bits shall be set to "000" or "111" and the receiver is required to ignore their content.

K4 (b5 - b7) coding and triggers

b5	b6	b7	Meaning	Triggers
0	0	1	No remote defect	No remote defect
0	1	0	E-RDI payload defect	PLM
1	0	1	E-RDI server defect	AIS, LOP
1	1	0	E-RDI connectivity defect	TIM, UNEQ

معلومات ذات صلة

- صفحات دعم المنتج الضوئي
- الدعم التقني والمستندات - Cisco Systems

ةمچرتل هذه لوج

ةللأل تاي نقتل نم ةومچم مادختساب دن تسمل اذه Cisco تچرت
ملاعلاء انءمچ يف نيمدختسمل معدى وتحم مي دقتل ةيرشبلاو
امك ةقيد نوك تنل ةللأل ةمچرت لصف انءمچال مچرئى. ةصاغل مهتغب
Cisco يلخت. فرتحم مچرت مامدقي يتل ةيفارتحال ةمچرتل عم لاعلا وه
ىلإ أمئاد عوچرلاب يصوت وتامچرتل هذه ةقदन ةتيلوئسم Cisco
Systems (رفوتم طبارلا) يلصلأل يزلچنلإل دن تسمل